

## MILL LINER BOLT TIGHTENING PROCEDURE

### Bolts are Supposed to Stretch

It is the slight stretching of a properly tightened bolt that provides the 'clamping force' that holds the bolted parts together.

For a bolt to do its job, this clamping force must be greater than the opposing force that is trying to pull the parts apart.

As long as the total forces attempting to stretch the bolt -the sum of the tensile load plus any opposing force -does not exceed the yield strength of the bolt, it will simply return to its original length when the bolt is loosened and those forces are removed.

But, if the yield strength is exceeded by the total tensile load, the bolt will be permanently stretched. When this happens the bolt is weakened and is rendered unsuitable for the same use.

Theoretically you would get the greatest strength from a given bolt by tightening it exactly to the yield point. However to provide a margin of safety, standard practice calls for tightening only to about 65% of yield strength.

To assure this safety margin and subsequent bolt fastener reliability, Donhad Pty Ltd recommends that grinding mill liner bolts be tightened according to the torque values below and the time schedule described in the table below.

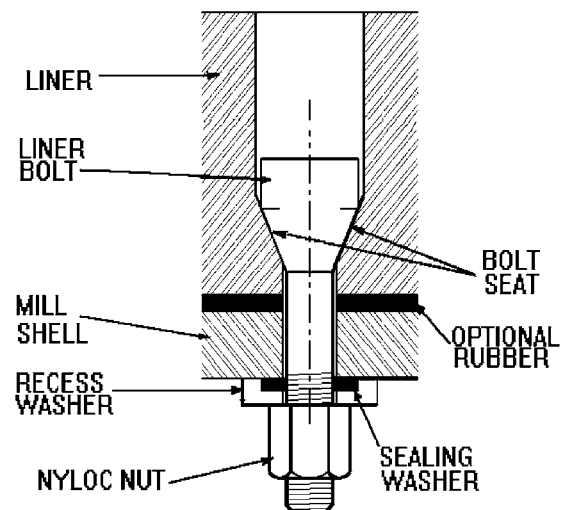

### Recommended Torque Values Nm (ft/lbs)

Bolt Diameter	Metric Property Class			
	Class 4.6	Class 8.8	Class 10.9	Class 12.9
<b>M36</b>	993 (731)	2649 (1953)	3664 (2702)	4282 (3158)
<b>M42</b>	1590 (1173)	4241 (3128)	5867 (4327)	6857 (5057)
<b>M48</b>	2389 (1762)	6370 (4698)	8812 (6499)	10299 (7595)

Bolt Diameter	Imperial Grade			NOTE: Torque values calculated to induce 75% of safe bolts load using light oil as a lubricant. Contact Donhad for values using other lubricants.
	Grade 2	Grade 5	Grade 8	
<b>1 1/4" UNC</b>	611 (451)	1368 (1008)	2218 (1635)	
<b>1 1/2" UNC</b>	1063 (784)	2380 (1755)	3859 (2846)	
<b>2" UNC</b>	2520 (1859)	5640 (4160)	9147 (6745)	

Time spent tightening all bolts properly, early in the liner's life, will promote maximum liner life and may save many hours of downtime later on. Using an accurately calibrated torque wrench, tighten bolts according to the torque values and schedule shown. Note that the torque values required depend both upon the bolt's diameter and its grade.

## Nut Selection

Nuts should be slightly softer than the bolt so that the nut threads can give the small amount necessary to exactly conform to the bolt thread contour. However if a nut is too soft, its threads may fail before sufficient clamping force is applied. (refer to *Tech Bulletin # 2*)

## Re-use of Fasteners

**Nuts** are the most dangerous component to re-use. The function of the nut is to deform slightly so that its threads will conform exactly to the bolt thread contour. When a nut is re-used with a different bolt, these distortions create friction as the nut/bolt assembly is tightened. This friction consumes a percentage of the torque applied during the bolt tightening process, leading to an actual under-tightened condition of the assembly.

**Bolts** can be re-used in an emergency with a new nut and washer assembly, but only after careful examination for wear, corrosion or damage to either the threads or the seat area. It should be noted that an over stretched or fatigued bolt would be virtually impossible to detect by eye and therefore the best and safest practice is to replace all used fasteners.

## Keep liner Bolts tightened Properly

**Bolts too loose** means that inadequate clamping force is being applied. This can allow the liner to move about during mill operation, resulting in wear and/or distortion to the mill head or shell bolt holes. This can also lead to bolt breakage through fatigue and ultimately to the liner coming loose from the shell.

**Bolts too tight** can cause bolts to permanently stretch. This weakens the bolt and reduces its ability to adequately clamp the liner to the mill shell. Consequences can be the same as for a too-loose bolt.

Loose bolts will also allow ground material to work between the liner and the mill head (or shell) and make it impossible to properly re-tighten the bolts. If this happens, the liner must be removed, mill and liner cleaned and liner reinstalled using the above re-tightening schedule.

## These can result in inaccurate torquing

**Incorrect air impact wrench output** due to inadequate air supply, dirty filter, water in air lines, etc. Check impact wrench output regularly against a recently calibrated torque wrench.

**Dirty or corroded bolt threads and nut threads** Dirt or corrosion create friction which produces inaccurate torque reading, resulting in under-tightening.

**Nature of the surface of bolted assembly** Rough surfaces add to tightening friction leading to undertensioning.

**Lubrication of bolt/nut assembly** Different lubricants have different coefficients of friction which can affect the amount of torque needed to achieve the required tension. Ensure that the torque value is relevant to the lubricant being used.

## Three critical Steps

- Be sure all tightening tools produce the torque required.
- Do not re-use bolts or nuts in critical applications.
- Take time to re-tighten bolts per recommended schedule.

### Explanation of Property Class of Material

In the ISO recommendation, the first figure in the property class number is the ultimate tensile strength in Mpa divided by 100, and the second figure is the proportion of yield stress to ultimate tensile strength so that multiplying the two figures together and then multiplying by 100, gives you the minimum yield stress.

#### Example

Property Class 8.8  
 Ultimate Tensile Strength of Material = 800Mpa  
 Therefore  $800/100 = 8$   
 Minimum Yield Stress of Material =  
 $8 \times 0.8 \times 100 = 640 \text{ Mpa}$

### Recommended Tightening Schedule

<b>First retightening</b>	After 1-2 hours of full load operation
<b>Second Retightening</b>	After 5-7 days of full load operation
<b>Ongoing</b>	Tighten every few days until further tightening is impossible.
<i>NB. Less critical applications need less critical tightening routines.            Eg. one piece shell liners need less attention than multiple piece castings like grate discharge assemblies.</i>	