

# TECHNICAL BULLETIN

BULLETIN#012 | REVISION#002

## *Easy-OutBolts*<sup>™</sup>

The patented *Easy-OutBolts*<sup>™</sup> are designed to reduce the potential for PERSONAL INJURY, DAMAGE TO EQUIPMENT and reduce LINER CHANGE-OUT TIMES.

The *Easy-OutBolts*<sup>™</sup> design consists of a standard liner bolt which has been modified to use in conjunction with a specially designed moil fitted to a standard hydraulic or pneumatic hammer. This feature suits any size of bolt.

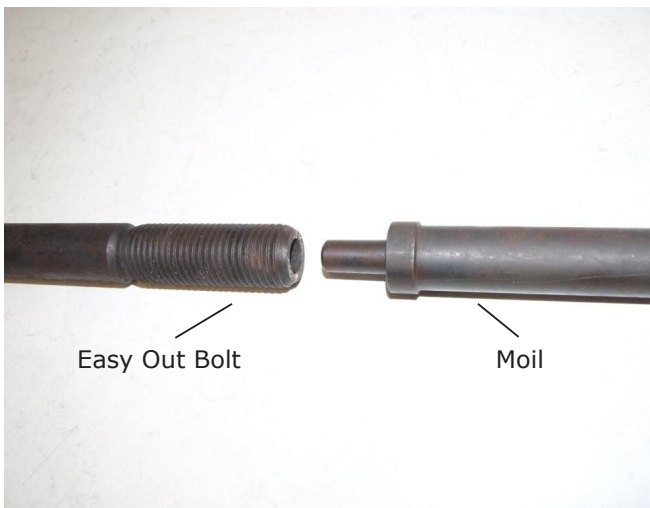

After removing the nut the moil can be inserted into the bolt end. Without the need to remove recessed or seal washers the bolt can be driven out of the liner and completely clear of the mill shell in one movement.

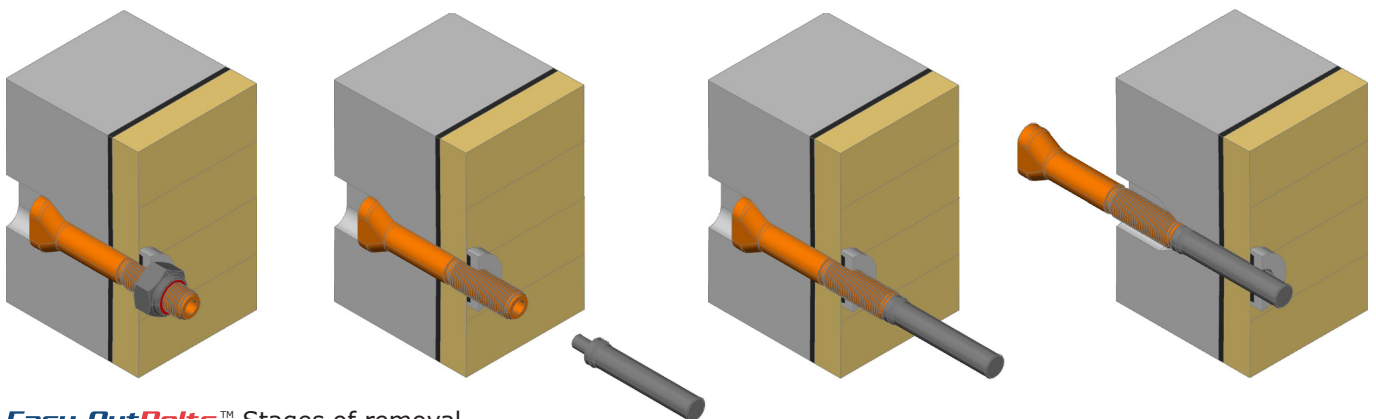

*Easy-OutBolts*<sup>™</sup> Stages of removal.

### Safety Benefits

- No more sledge hammers, minimising risks associated with manual handling and fatigue.
- No need for hand held or other such moil guides as there is a positive location between the moil and the bolt.

### Time Saving Benefits

- No need to remove washers as the bolt is pushed straight through and they collect on the moil.
- The moil and knock out hammer self align with the bolt.
- Drives the bolt out in one action.
- Removes the need for an extra man to hold drifts and/or moil guides in position. Reduces labour requirements.
- Bolt removal times on mills using *Easy-OutBolts* have been reduced by up to 65%. See the chart below for time reductions achieved during relines™ on three identical mills.

### No Mill Damage

- Prevents damage to seal areas around bolt holes and the hole itself, caused by the misalignment of knock out moils and misshapen bolts being forced through the hole, both of which ultimately lead to leakage.
- Ultrasonic wear measurement. The bottom of the *Easy-OutBolts*™ hole provides an opportunity to ultrasonically measure the bolt length and by extending the heads on some bolts in select positions in the mill the liner wear can be determined. This eliminates the need to access the mill to survey the liner wear, minimising down time due to lengthy and often complex isolation procedures.

